

**Key**

- B Distance from the keep aperture to the dead bolt aperture.  
With KL, kF, KiW, distance from keep aperture to bottom edge of striking plate
- C Height of dead bolt aperture
- D Width of dead bolt aperture
- G Distance from upper edge of striking plate to keep aperture
- L Overall length of the striking plate
- M Dimensions of fixing holes
- I Striking plate thickness

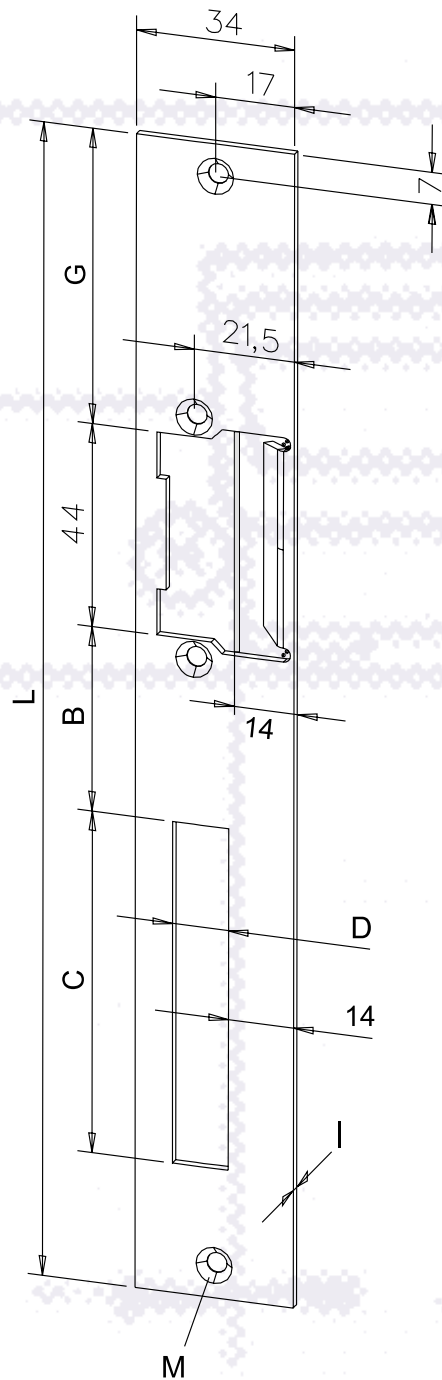

Flat striking plate 033

# FLAT STRIKING PLATES

WITH KEEP STANDARD  
2 FIXING HOLES

Standard see technical drawing left



	ORDER DATA				
	No.	033	034	851	282
Surface finishes*	Stainless steel	35	35	35	
	Galvanized and ground				40
	Polished brass				
	Yellow chromated				
	Gold-coloured	01			
	Grey	02	02		
	Black				
	White				
Dimensions	A				
	B	40	45	40	42
	C	74	74	45	74
	D	12	12	11	12
	E				
	F				
	G	64	64	64	94
	H				
	I	2	2	2	3
	L	250	250	250	280
	M	4,3 x 7,8	4,3 x 7,8	4,3 x 8	5,3 x 10,4
	N				
	O				
	P				
	R				
	S				
	T				
	U				
	V				
	X				
DIN orientation required	x	x	x	x	
Strike model	I4 UNI	x	x	x	x
	I4 DIN... (right-hand GRM)	x	x	x	x
	I4RR DIN	x	x	x	x
	I7, I16 UNI				
	I7RR, I16RR UNI				
	I9 UNI				
	I9 DIN				
	I42 DIN	x	x	x	x
	I42RR DIN	x	x	x	x
Special features			Prepared for model 878		

194

\* For more information on surface finishes see from page 236

# FLAT STRIKING PLATES

WITH KEEP STANDARD  
2 FIXING HOLES

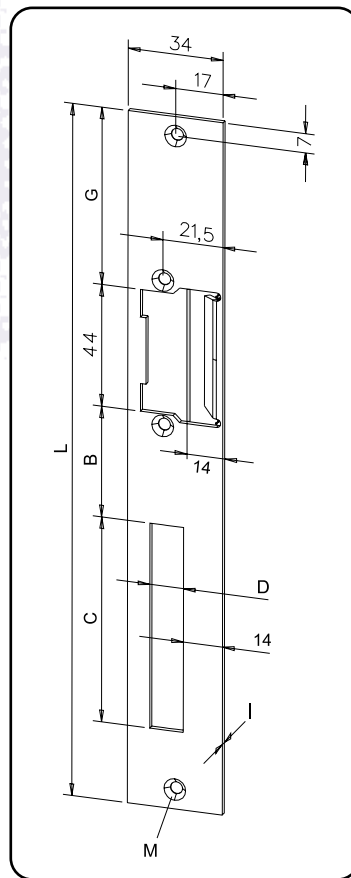

Flat striking plate 033

